



# FY-20A Flight Stabilization System installation & operation manual

Dear Pilot,

Thank you for purchasing the FY-20A stabilizer from FeiYu Tech. In order to achieve full potential and safe operation of this product, please carefully read this manual prior to installation.

**Warning:**

- The installation and use of this device require some skill and knowledge in flying remote controlled fixed wing aircraft.
- If you are a new to the hobby and have never flown one before, we do not recommend you install this device on your own.
- Please find assistance from an experienced flier who may provide you with the basic knowledge required to use this device successfully.
- If you are already an experienced flier, you will find the installation to be easy and logical. Just follow the instructions as stated in this manual and you won't go wrong.

You may e-mail us directly for assistance; [feiyudz@hotmail.com](mailto:feiyudz@hotmail.com)

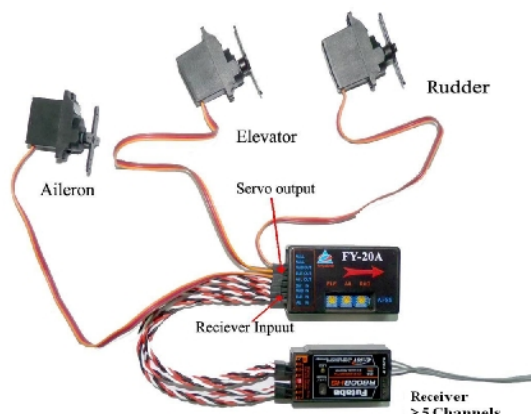

**OVERVIEW**

The FY-20A is a flight stabilizer for fixed wing aircraft based on inertial motion sensing. It utilizes a 3-axis gyroscope and 3-axis accelerometer to control the aircraft attitude in all 3 dimensions. The unit can be activated or de-activated via a spare channel from your receiver. Functions include:

- Level flight** – when you need it, the FY-20A will automatically level the flight attitude of your aircraft. If you are just learning to fly, this will help you gain experience, log more flying time and increase your confidence. The FY-20A can be left activated throughout the flight duration, from take off until you landing.
- Emergency Recovery** – in case you lose orientation or you feel the aircraft is out of control, activate the FY-20A via the switch and release of the control sticks. The FY-20A will automatically bring the plane back to level flight.
- Precision Flying**: For experienced pilot, FY-20A can help you achieve more leveled and precise flight paths, especially when flying and landing in strong wind.
- First Person View (FPV)**: For long distance flying or FPV, the FY-20A will take on the job of leveling the plane for you. Just point the plane where you want to go and enjoy the view!

**System Working Principle**

The Flight Stabilization System (FSS) in the FY-20A is an integrated 3-axis gyroscope and 3-axis accelerometer. This forms a comprehensive inertial based navigation platform that calculates 3D flight attitude using proprietary FeiYu Tech algorithm.

When activated in Balanced-Mode, the FSS detects any changes to the model's horizontal attitude. If attitude change is detected, the unit will send out controlling signals to the plane's ailerons, elevator and rudder to counter that change.

By continuously doing this, the plane is kept in a state of equilibrium, resulting in a smooth level flight. The aircraft pitch attitude (nose up or down) is automatically controlled via the elevator, while aircraft roll is controlled through the ailerons. Flight direction to the left or right is automatically corrected via the rudder servo.

To achieve level flight, the pilot need only release the flight control sticks (aileron, elevator, rudder) so that they return to the transmitter neutral (middle) position. The model will immediately revert to level flight.

When used in the 3D-Mode, if an aircraft is in an acrobatic flight, the activated FSS will automatically counter the rolling speed detected by the 3-axis gyros using all 3-axis controls (rudder, aileron and elevator). The plane will therefore maintain its last attitude state.

The FY-20A can be used in any environment both indoors and outdoors, and in any weather condition. After installation, it does not need any other initialization. Just switch on the power and your plane can take off in stable flight.

**FY-20A Package:**

In each box of FY-20A, you will receive the following:

- 1 x FY-20A circuit board.
- 4 x Receiver connecting wires
- 2 x double-sided tape or Velcro fastener
- 1 x shock absorbing platform with 4 rubber bands already installed
- 1 x instruction manual for FY-20A



**Technical Specification and working requirements:**

Input voltage : 4.0 to 6.0 Volts  
 Current draw : 52mA (5V)  
 Size : 55 x 33 x 20 mm(2.17 x 1.3 x .79 in)  
 Weight (excluding wires) : 20g(.71oz)  
 Temperature range : -25°C~ +70°C(-13°F~+150°F)  
 Maximum rate of rotation : ≤ 1200 ° / s

**Application**

The FY-20A can be installed in the following aircrafts:

- Normal / Traditional fixed-wing planes
- Delta-winged plane with rudder
- Delta-winged plane without rudder,
- Plane without aileron,
- V –tail plane with aileron
- V –tail plane without aileron
- Any other configuration, please e-mail us for enquiry: [feiyudz@hotmail.com](mailto:feiyudz@hotmail.com)

**Remote Control system requirement:**

The FY-20A has been tested to work with the following RC systems:

- Robbe-Futaba PPM / PCM 1024 / PCM G3 mode, 2.4 GHz systems;
- Graupner/JR PPM 8, PPM 12, SPCM mode;
- MPX PPM8, PPM 12 with UNI mode;
- Any remote control system using the standard of 1.5 ms neutral position.

**FY-20A Flight Modes**

- a) The FY-20A can be activated to fly in 3 flight modes. You may choose these flight modes via one free receiver channel and a 3-position switch from your computer radio:
- Mode 1 : FY-20A Deactivated.** In this mode, all control of the aircraft is by the pilot. FY-20A does not participate in flight control.
  - Mode 2: 3D-Mode.** In this mode, FY-20A will automatically recognize the latest position of the aircraft, and give controlling signal to keep the aircraft at the last attitude upon activation of 3D-Mode. All 3-axis will be stabilized, making your 3D acrobatic movement smoother. **However**, please note that this last attitude will be kept for less than 10 seconds. Continuous pilot input is still compulsory for safe aerobatic flying.
  - Mode 3: Auto balance mode.** When in this mode and with your transmitter control sticks at center, the FY-20A will continuously send out controlling signal (aileron, elevator, rudder) to ensure the aircraft maintains its horizontal level flight attitude and stable direction. In this mode FY-20A will not allow acrobatic flights.

b) To select the modes, set your End Points Adjustment (EPA) for the 3-Position Switch as follows:

Switch channel signal input	900-1200µs	1200-1800µs	1800-2100µs
Functional Mode	Auto balance mode	3D mode	Stabilization OFF

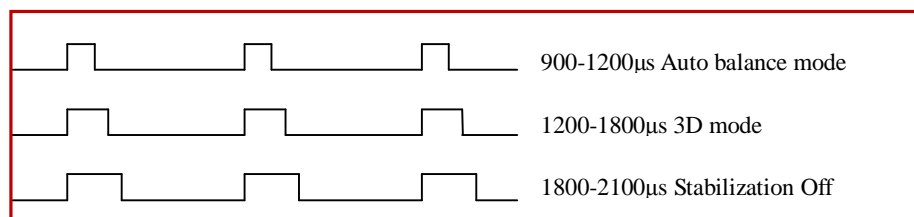

- c) You may also use a 2-position switch, at maximum and minimum End Points (EPA) to activate or deactivate flight stabilization (therefore omitting 3D-Mode).
- d) If the FY-20A does not detect any incoming signal to the Switch Channel Input, it will automatically engage Mode 3- **Auto Balance Mode**. However, we **DO NOT** recommend flying the unit with no signal input to the Switch Channel. It is possible that the auto balance will not function properly if the Switch channel is left open.
- e) We **DO NOT** recommend landing in Mode 2: 3D-Mode. In 3D-Mode the aircraft attitude is **not tuned** for smooth landing.
- f) Please note that the FY-20A operation **does not involve** the Throttle channel. The FY-20A has no control over your aircraft Throttle. Your throttle channel should be connected directly from your ESC to your Receiver (channel 3 for example), and operated in a safe manner.
- g) Warning: The Auto Balance Mode will provide a smoother leveled landing for your aircraft. However, note that the turning radius is much larger when FSS is activated. Please ensure your landing area has adequate clearance for this larger radius.

**Schematic diagram of stabilization control (Auto Balance Mode):**

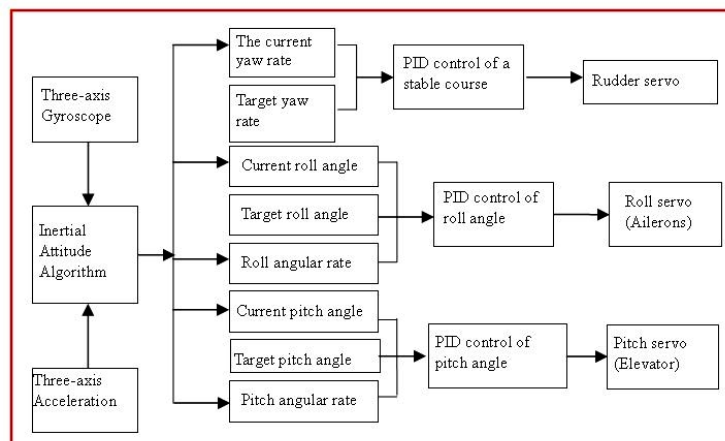

**IMPORTANT: RADIO PROGRAMMING**

- Remove all existing mixing function already programmed in your radio.
- The FY20A will do all the differential mixing, not your radio.
- Program your radio like a traditional plane layout (rudder, aileron and elevator).

**FY-20A Connection Interface**

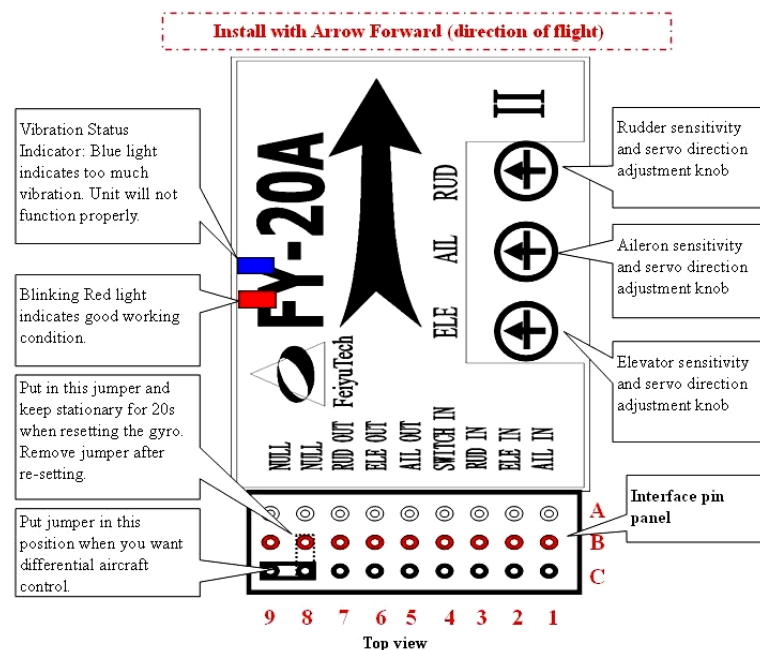

**The list of the pin Interface:**

9	8	7	6	5	4	3	2	1	No.
Not used	Not used	Signal Output to rudder	Signal Output to Elevator	Signal Output to Aileron	Signal Input for Mode Switch	Signal Input for rudder	Signal Input for elevator	Signal Input for aileron	A
Not used	Reset the gyro	Power to servo	Power to servo	Power to servo	Power to servo	Power to servo	Power to servo	Power to servo	B
Differential-mode	GND	GND	GND	GND	GND	GND	GND	GND	C

**Gyroscope initialization (re-setting):**

Out of the box, the FY-20A has been fully initialized. However, if the following conditions occur,

resetting and initialization is recommended:

1. The device has not been used for a long time.
2. There is a change in environmental temperature of over 30 degrees.
3. When in **Auto Balance Mode**, and the installed device in the horizontal position, the plane control surfaces begin to move and deflect by itself, without input from the pilot.

**Initialization / Reset Procedure**

Install the jumper as shown in this picture:

Power-ON the FY-20A and keep it stationary for at least 20 seconds. You will notice the red light blink with two different rates. After 20 seconds the re-setting / initialization is complete. Disconnect the power, unplug the jumper and remove (keep it in a safe place for future use).

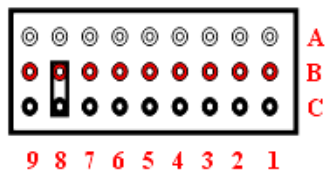

**NOTE:**

- Carry out this re-setting procedure only if the three conditions (above) occur. **We do not recommend regular scheduled re-setting.** It is NOT necessary and NOT recommended.
- The stabilizer unit does not need to be in a horizontal position during initialization. However, you must ensure there is no vibration during this process. If you suspect shaking had occurred, just restart the initialization / resetting process.

**Electrical Connection and Diagram**

**a) FY-20A Power**

- The FY-20A operates between 4 to 6 volts input.
- FY-20A is powered via the Receiver connection.
- If your plane is electric powered, the Receiver power supply is normally from the ESC. Alternately, you can supply the Receiver and FY-20A via a separate battery elimination circuit (BEC).

b) Connection between the FY-20A and RC Receiver output is via the supplied wire:

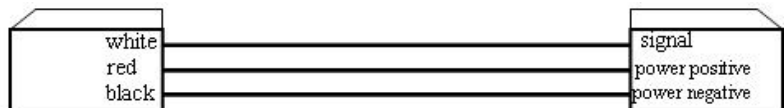

FY-20A requires a minimum of 5-channel RC receiver.

- 3 Receiver channels are used for aileron, elevator and rudder signal output. Connect these 3 receiver output signals to the FY-20A with the supplied wires.
- 1 Receiver channel is required to control the FY-20A working mode via a 3-position switch.

e) Example Minimum 5 channel receiver:

- Channel 1** = Aileron Signal Output
- Channel 2** = Elevator Signal Output
- Channel 3** = Throttle Signal Output
- Channel 4** = Rudder Signal Output,
- Channel 5** = Switch channel with 3-position switch to control FY-20A working modes.

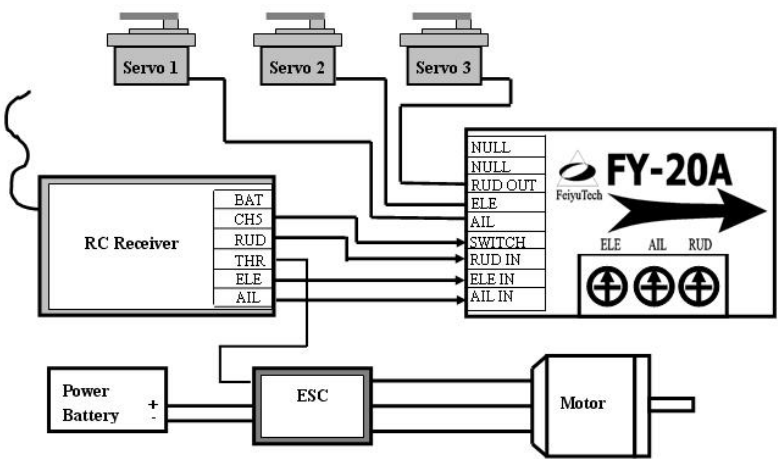

**Connection Warning**

Be very careful when you are plugging in your servos / connectors. Wrong installation can result in damage to your power supply or your Receiver.

Double check your installation and ensure ALL connectors are plugged in correctly. Example of wrong

installation:

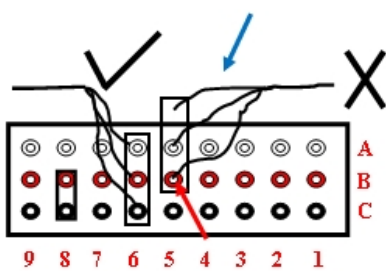

Servo (blue arrow) is plugged wrongly resulting in the signal wire (white) missing the FY20A signal pin. This results in the incoming power cable (RED) and servo wire (BLACK) short circuiting (red arrows). This will short circuit your battery or BEC! **DOUBLE CHECK YOUR INSTALLATION BEFORE FIRST TIME POWERING UP!**

**Plane Connection Layout:**

1) Normal / Traditional servo layout:

Servo 1	Servo 2	Servo 3
Aileron servo	Elevator servo	Rudder servo

2) Plane without aileron servo:

Servo 1	Servo 2	Servo 3
Rudder servo	Elevator servo	Don't connect

3) Delta-winged plane servo:

Servo 1	Servo 2	Servo 3
Differential servo 1	Differential servo 2	Rudder servo

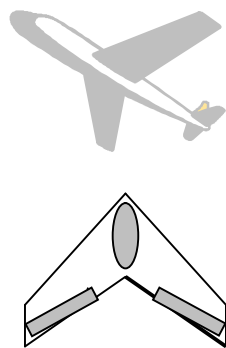

For all fix wing aircrafts (including the traditional rudder, aileron and elevator planes, and planes with aileron and elevator mixing, and so on) if the rudder is NOT used in any mixing function, you can have two options, as shown below:

1. Keep the FY20A rudder channel (RUD IN, RUD OUT) open (not used). Connect the Rudder servo directly to your RC Receiver.
2. Connect your Receiver Channel 4 to FY20A (RUD IN) and connect the rudder servo to RUD OUT.

**Aileron-Elevator Mixing**

For the following aircraft: Delta Wing with Elevator signal mixing (e.g. Flying wing Elevon):

Differential Output is carried out by using a jumper as shown here. The jumper has to be installed before powering ON. If you install it after powering ON, the mixing function will not take effect.

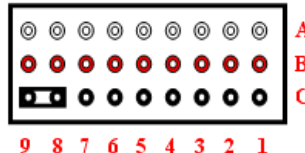

Do not remove this jumper. Leave it installed as long as you are using the mixing function.

**Rudder-Elevator Mixing**

The Jumper should NOT BE USED if you want to do Rudder-Elevator Mixing, because FY-20A does not support Differential-Mode stabilization for rudder-elevator mixing.

Therefore, the rudder-elevator differential control for V-tailed planes must have an add-on mixing device for the corresponding differential channel before connection to the servos:

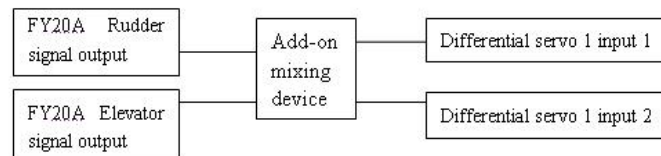

**VIBRATION CONTROL**

- The FSS in the FY-20A is vibration-sensitive. To optimize its stabilization capability, vibrations reaching the unit must be kept at a minimum.
- Therefore when installing this flight stabilizer, we highly recommend that you install it with the supplied shock absorbing platform.
- The algorithm in the FY-20A compensates for normal levels of flight vibration. However, if the vibration experienced by the unit exceeds the acceptable level, it will NOT work normally or may even stop working altogether.
- To keep vibration at a minimum, install the FY-20A away from the engine or any other vibration sources.
- The included shock-absorbing mount will meet the damping requirements of electric powered aircrafts and most gas / nitro planes.
- If you receive your shock absorbing mount uninstalled (A), assemble it as shown below (B):



- Use the supplied Velcro strips to mount the FY-20A to the suspended platform.
- Mount the entire unit to the plane using double sided tape (recommended), Velcro, screws or glue. Only the vibration damping pad is enough when the vibration is not so big.

The supplied Damper Mount will take care of most aircraft vibrations, unless it is (the vibration) too severe.

**WARNING: VIBRATION CHECK**

Even with the shock absorbing mount, your aircraft installation may not meet the damping requirements of the FSS. To confirm correct vibration damping, please follow this procedure:

- After connecting all wires between the Receiver, FY-20A and Servos, install the unit as recommended (ensure correct orientation).
- Run the plane engine or motor at different throttle levels. **DO NOT TAKE OFF.**
- Move the throttle level to different positions and maintain it for 20 seconds at each position.
- At each throttle position, observe the state of the red and blue lights flashing from the FY-20A.
- If the red and blue lights both stay **ON solid**, then the vibration dampening is not enough. You will need to add additional dampening support or change the installation location.
- If the red light maintains a steady flashing, and the blue light is OFF, this indicates the vibration dampening requirements have been met.

**FY-20A INSTALLATION: ORIENTATION, POSITION & LEVEL**

- The FY-20A has an arrow printed on the top of it. Orient the arrow towards the front of the craft (i.e. direction of flight).
- When installing, please keep the FY-20A horizontal and as close as possible to the "Centre of gravity" (CG) of the aircraft.
- The control benchmark of the FY-20A is its horizontal position. Therefore, ensure the FY-20A is in the horizontal position when the plane is in level flight.
- If there is deviation between the FY-20A horizontal position and the plane's level flight, it may cause the neutral value to be different between the **Manual Mode** and the auto **Balance Mode**. This difference may result in the following:

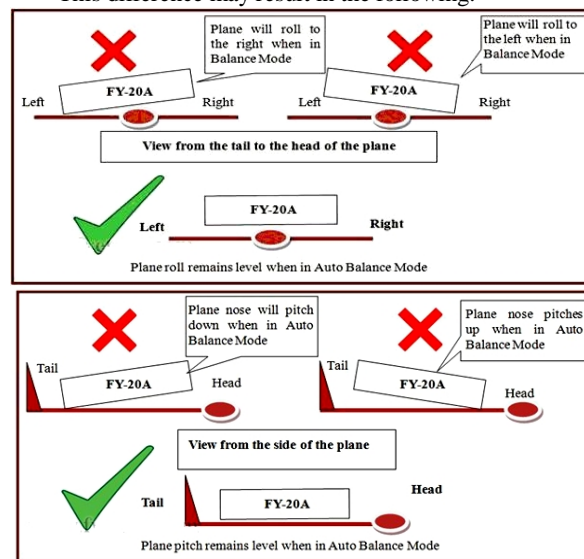

- We do not recommend using your transmitter trims to level your aircraft in Auto Balance mode, as the new trim settings will affect your aircraft when you revert to Manual Mode. It is best to land and adjust the FY-20A installation.

**FY-20A Pre-Flight Checking and Debugging**

**PRE-FLIGHT CHECK:**

The following procedure explains how to check for correct servo control direction upon FY-20A activation. You should also check that the FY-20A does not control the aircraft servos when in Mode 1 (Deactivated Mode).

**STEP 1: DIAL ADJUSTMENT**

Adjust the three dials on the FY-20A so that the arrow is in the middle, as shown below. Then rotate all dials in one direction (does not matter which direction):

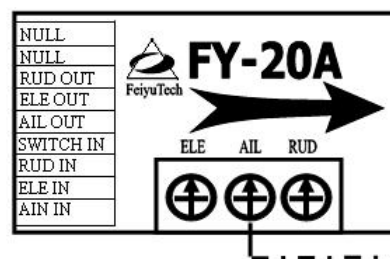

The knobs control both gain and servo direction. The gyro gain is lowest when the knob in the middle. i.e. The further away from center, the higher the gyro gain. Turning the knob left or right off-center will change servo direction.

## STEP 2: AUTO BALANCE MODE CHECK

Place the plane on a horizontal surface with both the wings and pitch leveled. Centre the rudder surface. Move the 3-position switch so that the FY-20A is in the **Auto Balance Mode**.

## STEP 3: AILERON CHECK

- Incline the plane to the right (roll right). The ailerons should give a control signal to counter this roll direction (see below). Similar action should occur when rolled to the left. If the ailerons move correctly, the knob has been turned in the correct direction. You can now adjust gain by moving nearer (low gain) or further away (high gain) from center:
- If the ailerons do not follow the movements shown above, simply turn the aileron knob to the opposite side (beyond centre). You should now see the correct servo movement.

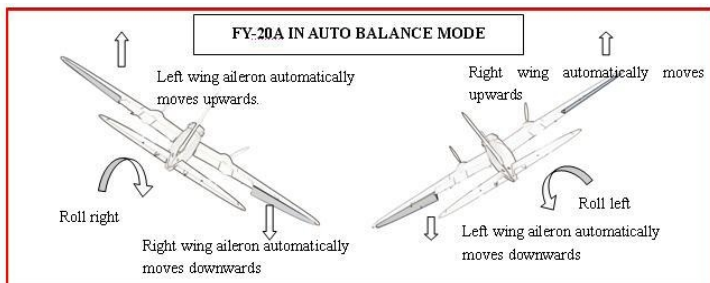

## STEP 4: ELEVATOR CHECK

- Incline the plane NOSE UP. You should see the elevator move down. And when you move the NOSE DOWN, the elevator should move up. Move the Elevator knob to the opposite side (from Centre) if the servo movement is incorrect:
- Adjust Elevator gain according to your aircraft requirement (lowest gain nearest to centre, highest gain further away from centre).

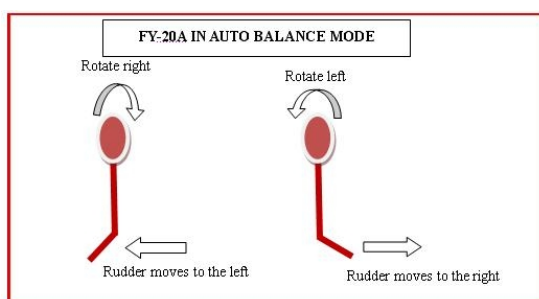
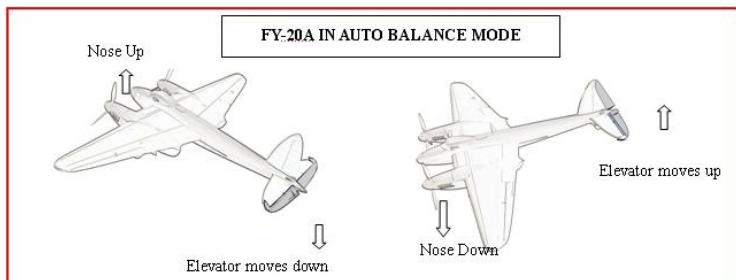

## STEP 5: RUDDER CHECK

- Rotate the plane at its centre axis from left to right. You should see the following action:
- Move the Rudder knob to the opposite side (from Centre) if the servo movement is incorrect:
- Adjust Rudder gain according to your aircraft requirement (lowest gain nearest to centre, highest gain further away from centre).

## STEP 6: FLIGHT TEST AND SENSITIVITY ADJUSTMENT

- Steps 1 to 5 should enable you to correctly set your servo movement direction via the 3 knob dials.
- To fine tune your aircraft attitude control via the FY-20A, some flight testing has to be performed.
- For the first flight it is recommended that the gains not be set too high. This will reduce large oscillation or 'flight overcorrection'.
- After the flight take off, switch the device from Mode 1 (deactivated) to Mode 3 (Auto-balance mode).
- If you see oscillation of the wings, this indicates the Aileron gain is set too high. Switch back to manual mode and land the airplane. Reduce the sensitivity (move dial towards centre position) and fly again. You should see improvement in wing attitude. Adjust until you are satisfied with the level of wing stabilization.
- Too much Elevator gain will show the tail moving up and down (rocking). Too much Rudder gain will show tail wagging. Reduce gain until this flight overcorrection is gone.
- Alternately, if you find the flight correction is not enough, you can increase gain accordingly.

## WARNING: SAFETY PRECAUTION – MUST READ

- The purpose of the FY-20A (FSS) is to stabilize the aircraft. It is not an Anti-Stall device. The stabilization action of the FY-20A will fail if the aircraft is stalled.
- The aircraft direction is controlled by you, at all times. Make sure you know where you are going.
- The FY-20A is for your enjoyment. Do not fly the plane into a crowded area, where your aircraft can cause serious injury if it were to crash. Please be responsible when using this product.
- Besides the regular pre-flight checks (we recommend a checklist), always check the correct operation of the stabilizer on the ground prior to take off.
- Any electronic hardware on an RC aircraft can fail over time. Please assess your aircraft and electronics condition before use. We are not responsible for any losses as a consequence of using this product.
- Please ask an experienced RC Plane pilot for assistance if you are a beginner. It is absolutely critical that you get flight basics before proceeding. You also need directions to correctly assemble, take off and control your RC Model. We highly recommend joining your local RC Modeling club.
- Never fly close to people, buildings, wires, vehicles, trees or closed spaces. You could seriously injure someone.
- Minimum flying distance should be 20 feet from yourself or others. Learn about emergency procedures should you lose control of your aircraft.
- Keep the RC Model and the related equipment away from children. RC planes are not toys. Children must be supervised at all times if they are allowed to fly.
- Please operate your RC plane within the permitted area of your local government. For more details, please check with your local council or government.
- If you are not using 2.4 GHz spread spectrum radio, never turn on your radio before checking and re-checking that you're the only one using the frequency. You could cause a crash of another aircraft if the frequency is the same. For security; please obey to the local frequency regulation.
- Never use the remote control within three miles of your local airport. You could endanger full scale aircraft instruments. Lives could be lost.
- Keep all electrical equipment away from rain water, moisture and extreme high temperature.
- DO NOT OPEN any FY-TECH Attitude Flight Stabilization System (AFSS) unit or any of our other modules. Opening or dismantling the module cover will null any kind of warranty we and our distributor have on the product you purchased.

## Installation Start-Up Guide

### Description:

**Aircraft:** Electric 3D plane,

**Product:** FY-20A stabilizer and wirings;

**Radio:** FUTABA T8FG

**Receiver:** FUTABA R617FS

### A. Installation equipment:

- Scissors

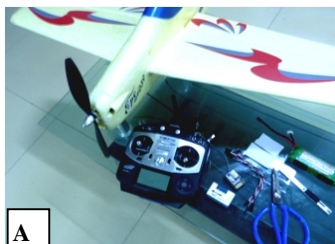

- Sharp knife
- Test battery
- Velcro and double sided tape

### B. Wiring Installation

- Insert Receiver CH1 to the AIL\_IN
- CH2 to the ELE IN
- CH4 to the RUD IN
- CH5 to the SWITCH IN.

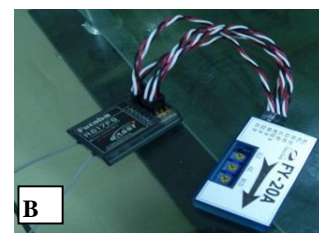

### C. Plane cockpit area:

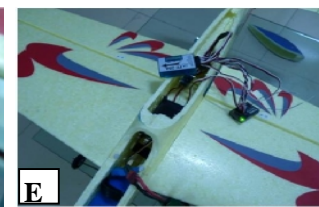
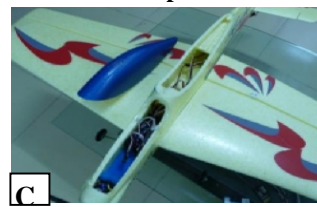

### D. Shock absorbing platform with Velcro attached.

Install this platform inside the plane, preferably at the centre of gravity (CG).

### E. Connect the FY-20A to Receiver

- ESC signal input to CH3 receiver
- Aileron servo to AIL OUT of FY-20A
- Elevator servo to ELE OUT of FY-20A
- Rudder servo to RUD OUT of FY-20A



### F. FY-20A Installation

Use double-sided taped Velcro to stick the FY-20A inside the plane. We highly recommend using the included vibration damping platform.

Install the FY-20A Horizontally. Ensure that you install the unit with the Arrow pointing towards the aircraft nose (direction of flight). Also ensure that the receiver is fixed firmly.



### G. Set CH5 to to any 3-position switch on your transmitter (to select 3 modes control) or 2-position switch (to activate or deactivate FSS only).

### H. Turn on your transmitter and connect power to your plane(Be sure to remove the propeller!).

- Adjust the three dial knobs. Turn all in one direction.
- Switch the FY-20A to Mode 3 (Auto Balance Mode) via the SE switch.
- Check for the correct movement direction of each servo
- Reverse dial knob rotation if servo counter movement is not moving correctly.
- Aileron:** if the plane rolled left ,the FY-20A stabilizer automatically moves the aileron to roll right. If plane is rolled to the right ,the FY-20A stabilizer automatically counters to roll the plane to the left. If the control direction is wrong, rotate the AIL dial knob in the opposite direction.

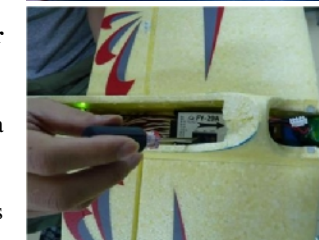

- Elevator:** if the plane nose is pitched up, the FY-20A stabilizer automatically moves elevator down. If the plane is pitched down ,the FY-20A stabilizer automatically moves the elevator up. If the control direction is wrong, rotate the ELE dial knob in the opposite direction.



- Rudder:** If the plane's nose is rotated to the right rapidly, the FY-20A stabilizer automatically moves the rudder to the left. If the plane's nose is rotated to the left, the rudder will automatically move to the right. If the control direction is wrong, rotate the RUD dial knob in the opposite direction.

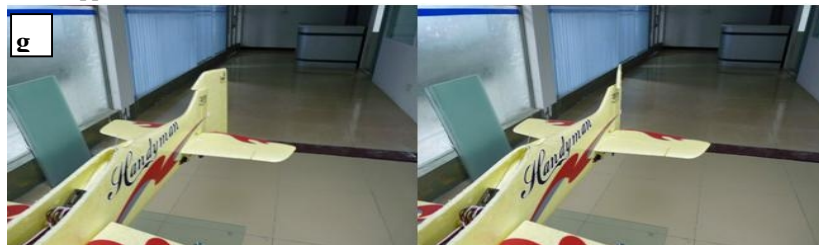

- Check that the FY-20A is installed firmly on the vibration-absorbing mount. Close the cockpit. Installation is completed. Test fly to adjust gain.



**Note:** FeiYu Tech reserves the right to change this manual at any time.